

MAGIC SWITCH

Voluntary opening sensor for all types of automatic doors

Detection & Hygiene

The radar technology serving sensitive environments

The MAGIC SWITCH, used as a contactless switch, integrates the market safest technology for motion detection : the Doppler effect technology that ensures a high quality of detection.

Thanks to this technology, the MAGIC SWITCH is :

- stable and reliable
- suitable for a large number of environments
- particularly well-suited for applications in hospitals, food processing or pharmaceutical sectors. It also allows ease of access for the disabled arriving in front of a low energy automatic door

Contactless opening

The opening is activated by simple hand moves [push or oscillation effect] in front of the sensor. It is not necessary to put the hand on the sensor. This feature guarantees absolute hygiene, which is necessary in some environments.

- possibility to keep the door open in "toggle" mode
- in "impulse" mode, the door will close after the passing through

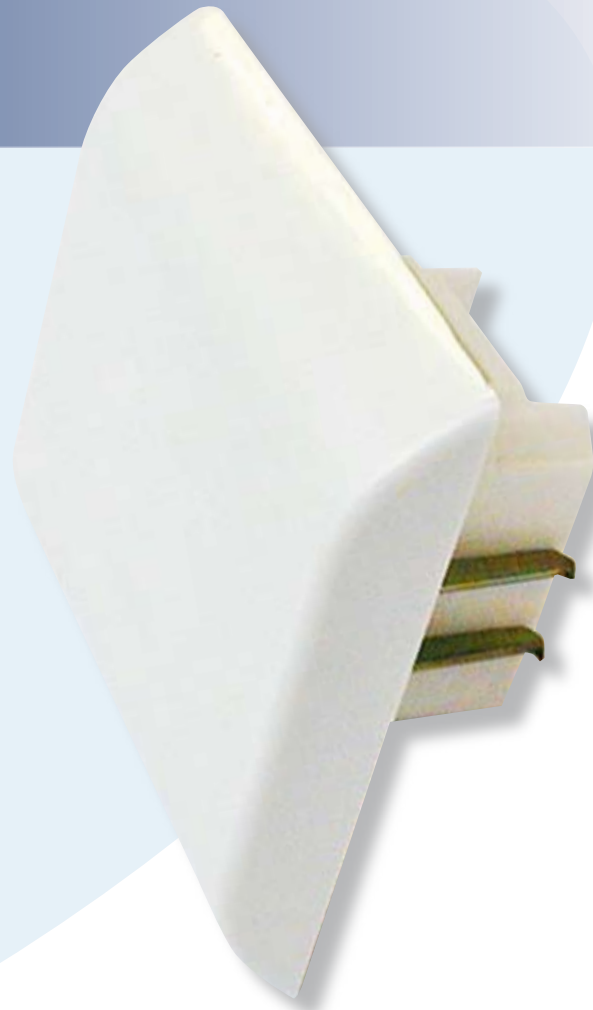

The Pros

- fully snap-on mechanics
- LED [blue] lights on when there is a detection
- can be completely recessed into any surface [except for metallic]
- laser engraving on the housing, indelible even with high pressure cleaning

Types of doors

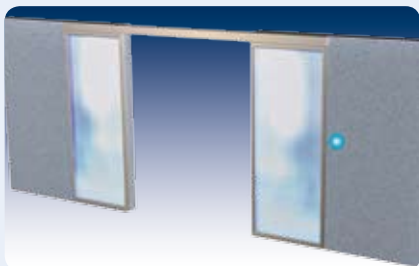

Sliding doors

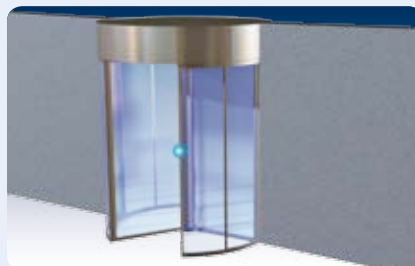

Revolving doors

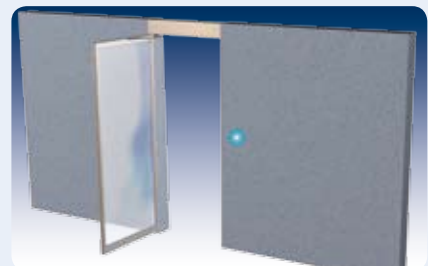

Swinging doors

Technical specifications

Technology :	Microwave motion sensor
Radiated frequency :	24.150 GHz
Detection range [hand] :	+/- 10 - 50 cm if movement towards sensor at 90° (adjustable)*
Detection mode :	Motion (bidirectional)
Speed of target :	Min. 5Hz or +/- 3cm/s, max. 200Hz or +/- 1.2m/s
Supply voltage :	12 - 24V AC +/- 10% 12 - 24V DC +30% / - 10%
Power consumption :	< 1.2W
Output :	Relay with switch-over contact (free of potential)
Output hold time :	0.5s (in PULSE mode)
Temperature range :	-20°C - +55°C
Norm conformity :	Electromagnetic compatibility (EMC) according to 2004/108/EC
Degree of protection :	IP52 (when recessed in the wall plus sealed with silicone or when flush mounted with a BEA accessory)
Material :	ABS
Colour :	White

Specifications are subject to changes without prior notice

* The adjustment of the detection field below 10cm is possible, but the detection capability of the sensor can not be guaranteed!

Dimensions

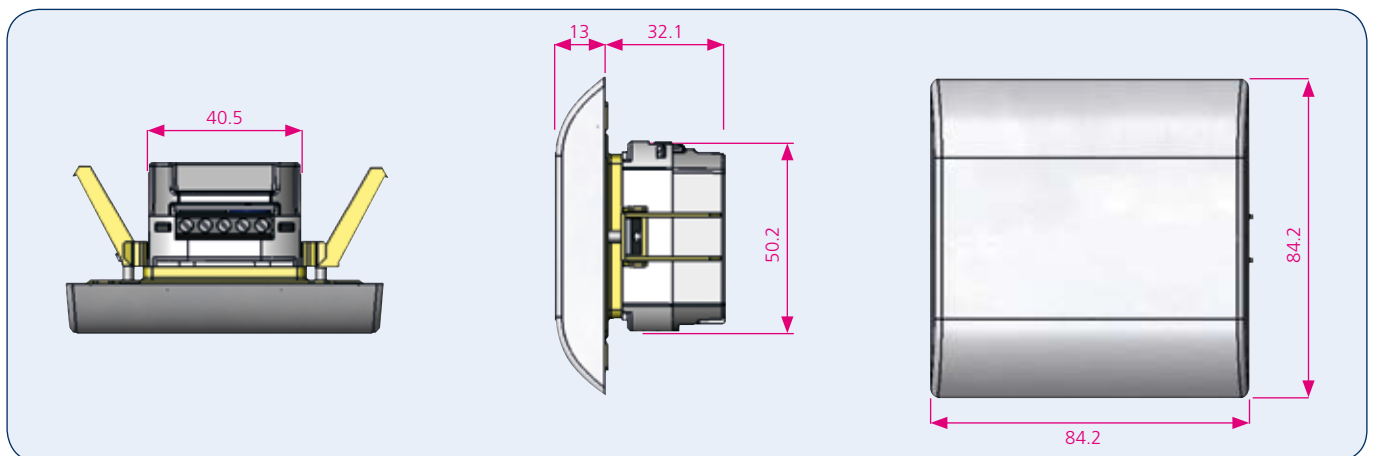

Accessories and options

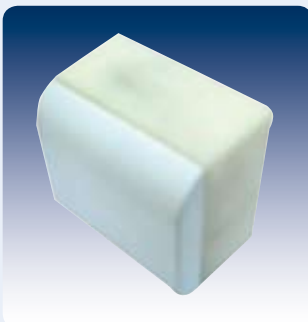

Surface mount box



Your company logo in laser engraving



Logo in laser engraving



Switch for either "toggle" or "impulse" mode